

CRL

Central Research Laboratories

a DESTACO company



Transfer Systems

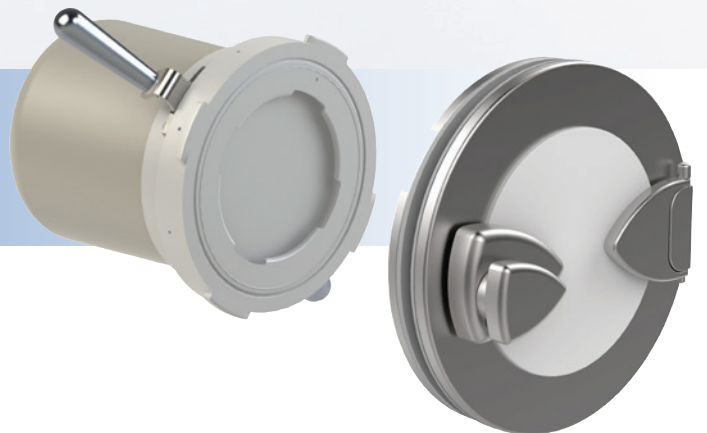

Visual Selection Guide | Life Science

1

Z

DR
T

DR
T

r

A Legacy of Innovative Experience

In 1945, at the dawn of the Atomic Age, three scientists from the Massachusetts Institute of Technology founded Central Research Laboratories (CRL) and pioneered early development of safer methods for handling hazardous and toxic products produced by this industry. With a legacy of over 70 years of innovative experience, CRL has continued to develop and build a full line of remote handling and containment solutions including Telemanipulators, Transfer Systems, Glove Ports, and Waste Drum Transfer Systems. These products allow operators to safely and efficiently perform various tasks in Nuclear and Life Science industries across the world.

The CRL team has the experience, expertise, and technologies to help with all your remote handling needs and strives to continually improve and develop innovative technology that help its customers achieve the highest level of performance. CRL is committed to its customers' needs and developing the best solutions for every project. Every product manufactured is created with those specific needs in mind to deliver the most customized solution available for every application.

crlsolutions.com

Central Research
laboratories

RED WING, MINN.

Proven Technology. Customized Solutions.

Transfer Systems

For safe and contained transfer of product or components into or out of isolation

CRL Transfer Systems provide safe, contained transfer into or out of isolation; consisting of two main components, the alpha assembly and the beta assembly. The alpha assembly is normally mounted to the cell wall of a contained environment and the beta assembly is mobile and connected to a container, bag, or process component. When the two assemblies are mated, toxic or sterile materials can be rapidly transferred in and out of isolation without breaking containment, while maintaining the safety of the product and/or operators.

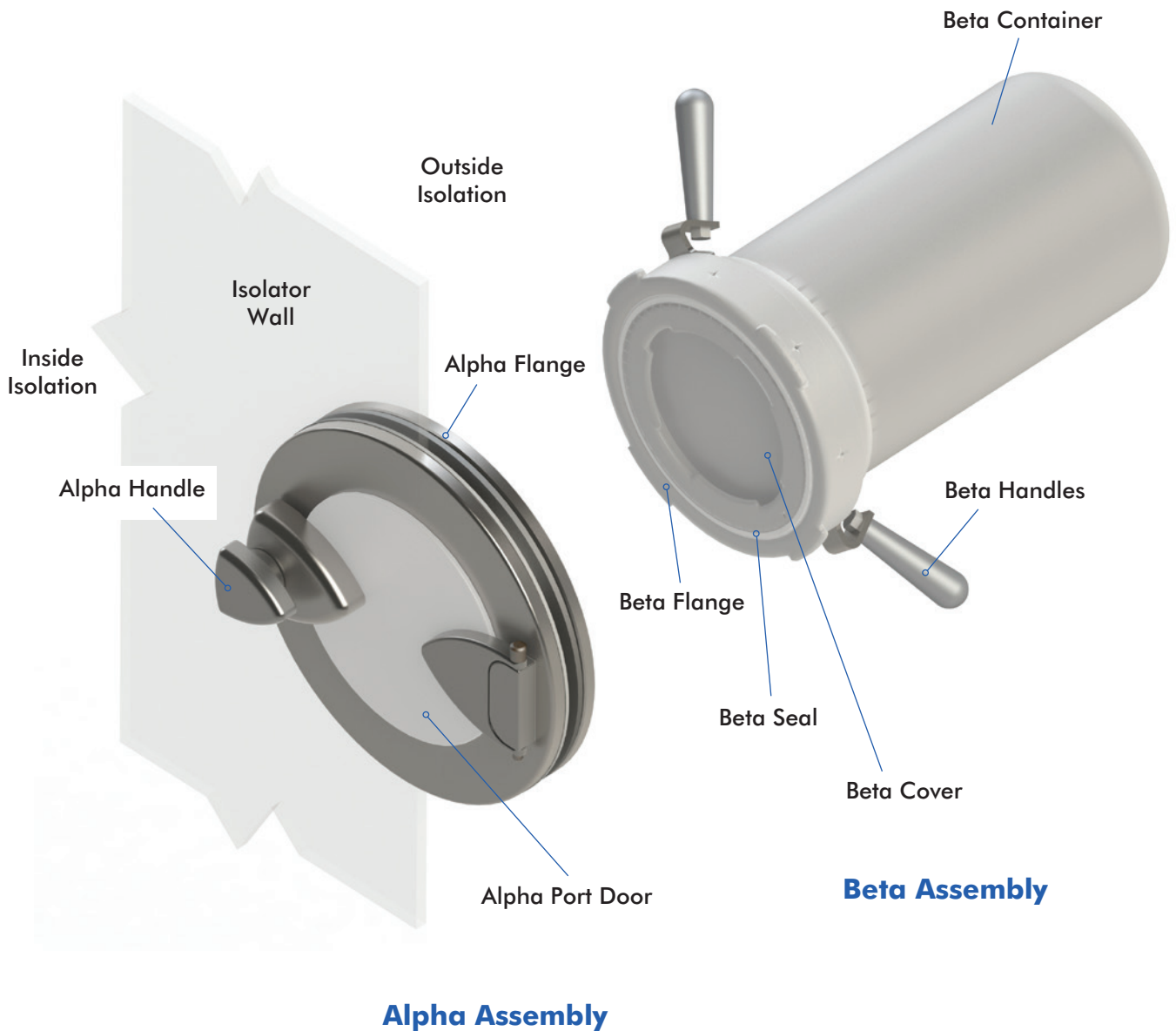

Central Research Laboratories

BETA LAB

Right Solutions. Right Partner. Exceptional Value.

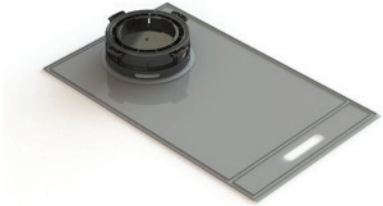
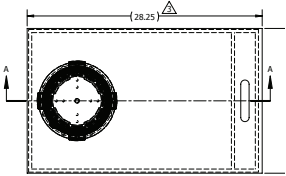
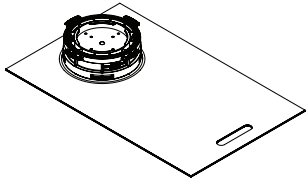
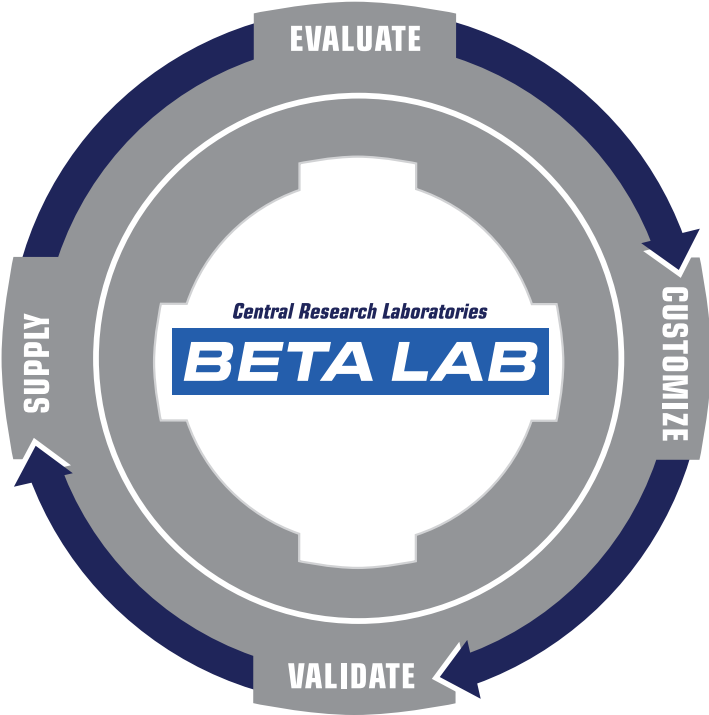

Beta Lab is a customizable service for all your transfer needs. When off-the-shelf or standard product offerings don't cut it, Beta Lab works with you to develop the perfect solution for your application. Offering exceptional value and endless possibilities.

EVALUATE

To provide the best solutions, we must first understand your needs. We'll work with you to understand your process and determine what transfer solution best suits your needs and budget.

CUSTOMIZE

After requirements are established, we utilize our proven technologies and expertise to customize the perfect solution for your application.

VALIDATE

A first-run product is provided to test the functionality and assist in the validation process needed to move forward with use in your process.

SUPPLY

After validation, we provide the final solution for use in your application. Multiple material vendors are sourced for an uninterrupted, readily available supply.

Clean Rapid Transfer Ports (CRTP)

For clean, rapid and repeatable transfer

Designed for ease of cleaning and minimized glove issues due to new, improved handle design

- Rapid repeatable transfers without breaking containment
- Mechanical interlocks to prevent improper port operation
- 316L Stainless Steel with multiple door options available
- Available in 105, 190, 270, 350 sizes

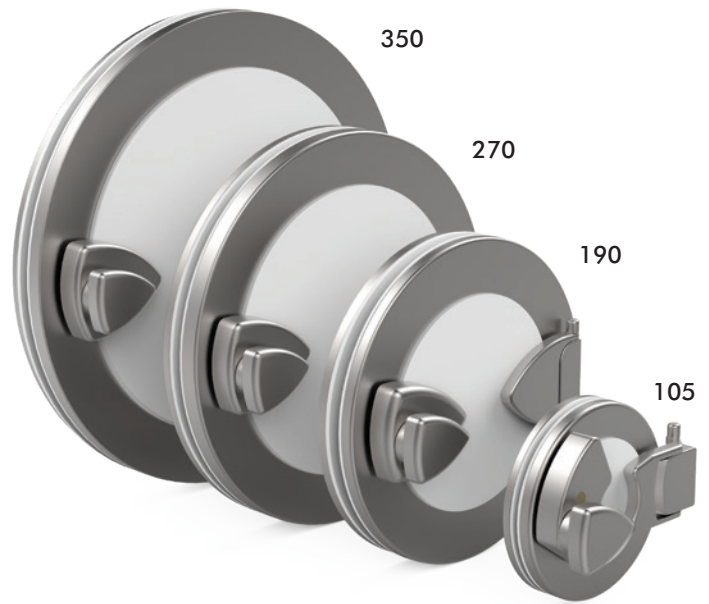

Interlock System

The CRTP features mechanical interlocks that prevent the improper operation of the transfer port.

The interlocks are incorporated into the alpha flange and prevent actions that could compromise the containment and sterility of the isolator, such as: the alpha port door from being opened when a beta flange has not been docked, or the beta flange from being removed from the alpha flange when the alpha port door is open.

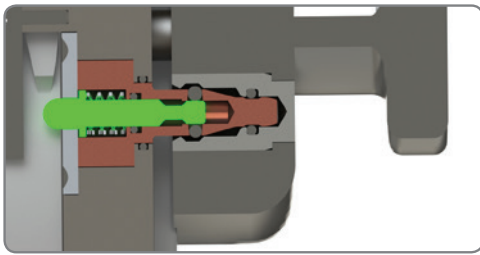

Port door interlock (shown in locked position), beta assembly not docked.

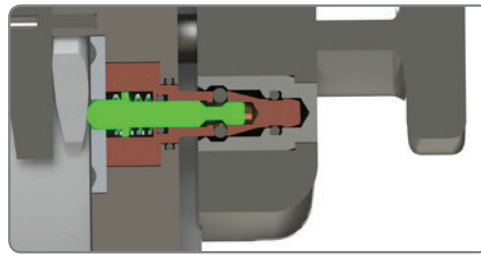

Port door interlock (shown in unlocked position), beta assembly docked.

Beta Mount Inserts

The CTP's interchangeable beta mount inserts can be replaced without breaking containment. This allows never before seen versatility.

4-Bayonet Insert

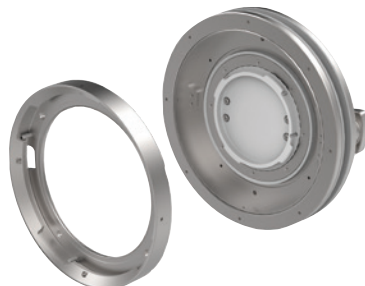
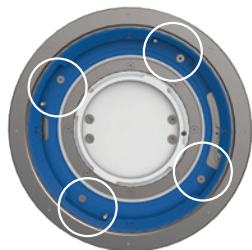

3-Bayonet Insert

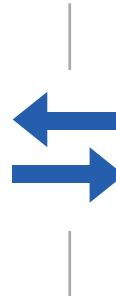
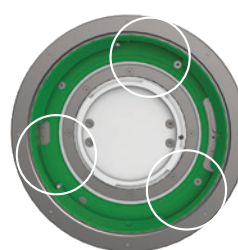

Item	Size	Description
CRL-CRTP-105-SS	105	Alpha Flange Assembly - Stainless Steel Flange & Port Door with Interlocks
CRL-CRTP-105-PP		Alpha Flange Assembly - Stainless Steel Flange & Polypropylene Port Door with Interlocks
CRL-CRTP-105-LT		Alpha Flange Assembly - Stainless Steel Flange & Polypropylene Port Door with Interlocks, Liquid Transfer
CRL-CRTP-190-SS	190	Alpha Flange Assembly - Stainless Steel Flange & Port Door with Interlocks
CRL-CRTP-190-PP		Alpha Flange Assembly - Stainless Steel Flange & Polypropylene Port Door with Interlocks
CRL-CRTP-190-LT		Alpha Flange Assembly - Stainless Steel Flange & Polypropylene Port Door with Interlocks, Liquid Transfer
CRL-CRTP-270-SS	270	Alpha Flange Assembly - Stainless Steel Flange & Port Door with Interlocks
CRL-CRTP-270-PP		Alpha Flange Assembly - Stainless Steel Flange & Polypropylene Port Door with Interlocks
CRL-CRTP-350-SS	350	Alpha Flange Assembly - Stainless Steel Flange & Port Door with Interlocks
CRL-CRTP-350-PP		Alpha Flange Assembly - Stainless Steel Flange & Polypropylene Port Door with Interlocks



Stainless Steel Door (SS)
(Typically used in strong
chemical/radiation or some
aseptic applications)



Polypropylene Door (PP)
(Typically used in
pharma, chemical, and
nuclear applications)

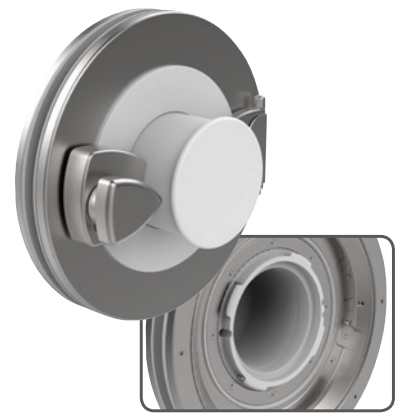

Liquid Transfer Door (LT)
(Typically used in
filling line and fluid
transfer applications)

Sterilizable Rapid Transfer Ports (S RTP)

For transfer of materials (stoppers, vials, caps, etc.) into a sterile isolator or aseptic barrier system requiring a high sterility assurance level

A reduced cost manual double-door system that consists of an alpha assembly featuring CRL's patented dry-heat technology. Unlike UV sterilization techniques, our dry heat sterilization method eliminates concerns often associated with contaminated seals resulting from inconsistent aseptic wiping or shadowing and stacking.

- Independent tests have shown that a 6-log microbial reduction can be achieved at the sealing surfaces of the S RTP
- Electric heater installed in alpha port flange at intersection of seals (high temperature zone)
- Critical zone is heated to 190° C and held for predetermined time after alpha & beta are docked



Design Features

- 316L stainless steel alpha flange with polypropylene or stainless steel door
- Silicone gasket seals
- Molded medical grade polymer beta flange with polypropylene container
- Polypropylene or stainless steel protective collar to cover Ring-of-Concern

Item	Size	Description
CRL-44010	190	Sterilizable Rapid Transfer Port (S RTP)

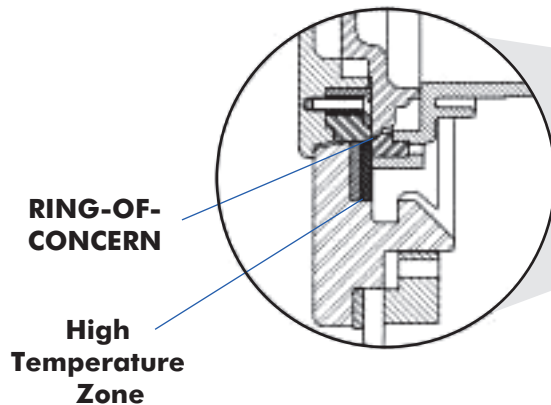
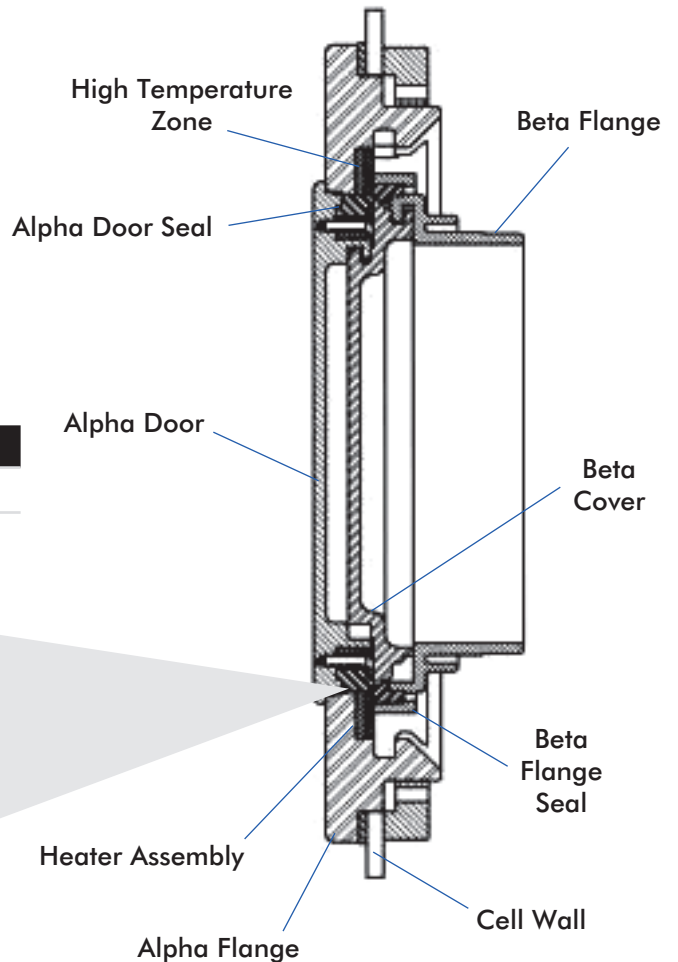

Standard Beta Containers

For safe and contained transport or storage of product, components, samples, and waste

- Gas tight design
- Multiple materials, sizes and lengths available



Item	Size	Length ([in.] mm)
Beta Canister Assembly (Polypropylene)		
CRL-41204-4.00	105	[4.00] 101.6
CRL-41204-8.00		[8.00] 203.2
CRL-41204-12.00		[12.00] 304.8
CRL-41204-18.00		[18.00] 457.2
CRL-41204-24.00		[24.00] 609.6
CRL-41278-8.00	190	[8.00] 203.2
CRL-41278-16.00		[16.00] 406.4
CRL-41278-24.00		[24.00] 609.6
CRL-41180-16.00	270	[16.00] 304.8
CRL-41180-24.00		[24.00] 609.6
CRL-41181-12.00	350	[12.00] 304.8
CRL-41181-24.00		[24.00] 609.6
Beta Canister Assembly (Stainless Steel)		
CRL-41599-11.81	105	[11.81] 300
CRL-41599-16.00		[16.00] 406.4
CRL-41249-23.62	190	[23.62] 600
CRL-41598-24.00	270	[24.00] 609.6
CRL-41228-15.75	350	[15.75] 400

Note: Please contact CRL for custom container lengths and specific overall dimensions.

Autoclaveable Beta Containers

For moist heat sterilization of tools and components for aseptic transfer into isolation

- For use with 1.5 in. Tri-Clamp vent port with 0.2 μm filter and housing
- Available in 316L Stainless Steel and anodized Aluminum
- Stainless Steel perforated baskets available to ease unloading and improve sterilization process



Item	Size	Length ([in.] mm)
Aluminum		
CRL-44356-8.00	105	[8.00] 203.2
CRL-44359-15.75	190	[15.75] 400
CRL-41201-16.00	270	[16.00] 406.4
CRL-41580-16.00	350	[16.00] 406.4
CRL-41580-24.00		[24.00] 609.6
Stainless Steel		
CRL-41253-8.00	105	[8.00] 203.2
CRL-42070-16.00	190	[16.00] 406.4
CRL-41582-15.75	270	[15.75] 400
CRL-41581-16.00	350	[16.00] 406.4

Hydrophobic Filter & Housing with Clamp

CRL-48289 - Housing w/ Filter Cartridge & Clamp

CRL-95860 - Filter Cartridge (requires housing)

Note: The lengths shown are only for the container and do not include the additional length added by the bottom container support legs. Please contact CRL for custom container lengths and specific overall dimensions.

Beta Bags

For sterilization and transfer of components into isolation

- Tyvek®, HDPE, PVC and other materials available
- Gas tight design
- Available in multiple port and bag sizes
- Produced in Class 7 Clean Room
- Autoclave and gamma sterilizable versions

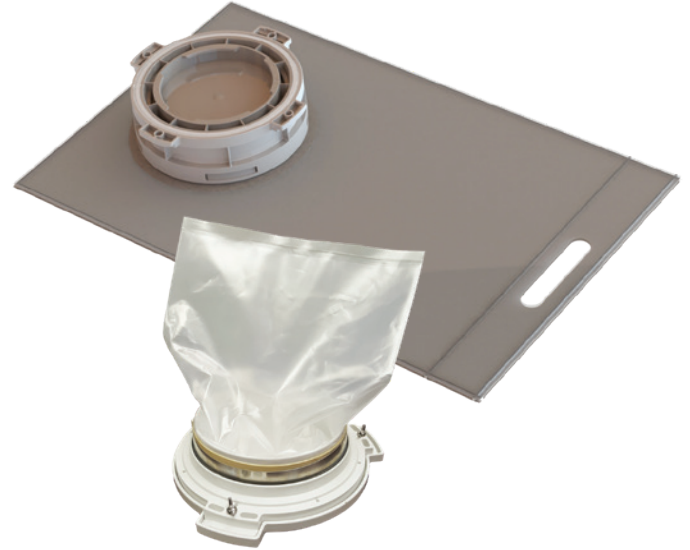

Please contact CRL for specific sizes, lengths and requirements.

Sterile Liquid Transfer Ports (SLTP)

For safe, aseptic, cost-effective transfer of sterile liquid from bulk tank into isolation

- Tank and SLTP Steam In Place (SIP) sterilized together
- Cost-effective, multiple use system
- Safe for aseptic and aseptic/potent liquid transfer

Item	Size	Description
CRL-SLTP-105	105	Sterile Liquid Transfer Port (Stainless Steel)
CRL-SLTP-105-SIP	105	Steam In Place (SIP) Docking Plate (Stainless Steel)
CRL-SLTP-190	190	Sterile Liquid Transfer Port (Stainless Steel)
CRL-SLTP-190-SIP	190	Steam In Place (SIP) Docking Plate (Stainless Steel)

Note: SLTP for use with 105 and 190 CRTP with Liquid Transfer door only (P.6)

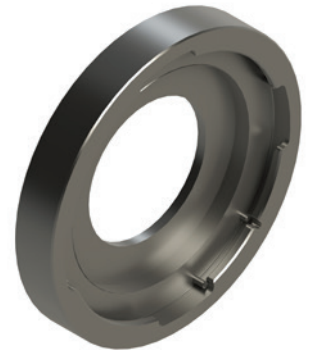
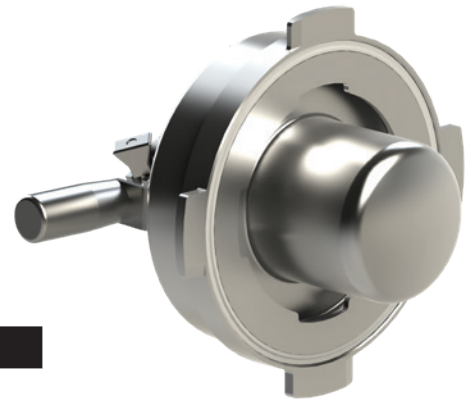

Steam in Place (SIP)
Docking Plate

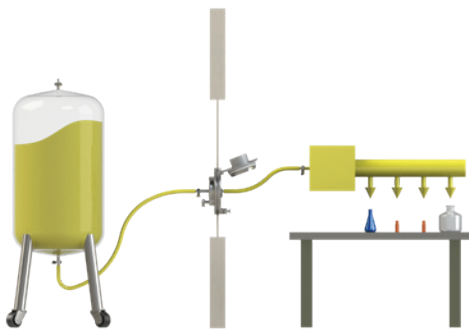

Alpha Sterilizing Cover

For sterilization of the entire alpha port door, seal, and flange surface (by a VHP process, for example)

- Containment is maintained while port door is open during sterilization process



Item	Size	Description
CRTP		
CRL-CRTP-105-SC	105	CRTP Sterilization Cover Assembly (Polypropylene)
CRL-CRTP-190-SC	190	
CRL-CRTP-270-SC	270	
CRL-CRTP-350-SC	350	
Legacy RTP		
CRL-44357	105	RTP Sterilization Cover Assembly (Polypropylene)
CRL-44360	190	
CRL-43402	270	
CRL-43401	350	
CRL-43789	460	

Beta Bag Flange Assembly

For product and component transfer into or out of isolation in potent applications

- Beta Bag Flange used with disposable bags
- Safe transfer of products, components or tools into or out of toxic containment

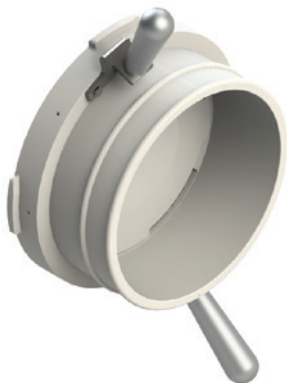

Item	Size	Description
CRL-41032	105	Beta Bagging Flange Assembly - One Rib (Polypropylene)
CRL-42657		Beta Bagging Flange Assembly - Two Rib (Polypropylene)
CRL-41021	190	Beta Bagging Flange Assembly - One Rib (Polypropylene)
CRL-41022		Beta Bagging Flange Assembly - Two Rib (Polypropylene)
CRL-41000	270	Beta Bagging Flange Assembly - One Rib (Polypropylene)
CRL-41001		Beta Bagging Flange Assembly - Two Rib (Polypropylene)
CRL-44198		Beta Bagging Flange Assembly (Ultem®)
CRL-41038	350	Beta Bagging Flange Assembly - Two Rib (Polypropylene)
CRL-41037		Beta Bagging Flange Assembly - One Rib (Polypropylene)
CRL-44311		Beta Bagging Flange Assembly (Ultem®)
CRL-43790	460	Beta Bagging Flange Assembly (Polypropylene)

Ultem® is a Registered Trademark of GE.

Beta Flange with Tri-Clamp Fitting

For connection of large tanks and process equipment to isolation

- Charging of formulation tanks and reactors
- Discharging from dryers
- Charging of a mill

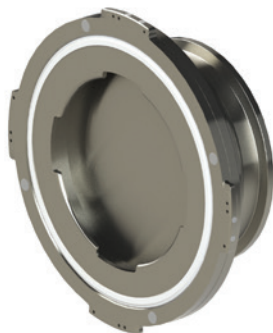

Item	Size	Description
CRL-45086	105	Beta Flange Assembly - 3 inch Triclover (Stainless Steel)
CRL-41030		Beta Flange Assembly - 4 inch Tri-clover (Stainless Steel)
CRL-47296		Beta Flange Assembly - 4 inch Triclover (Polypropylene)
CRL-46045	190	Beta Flange Assembly - 4 inch Tri-clover (Stainless Steel)
CRL-41019		Beta Flange Assembly - 6 inch Tri-clover (Polypropylene)
CRL-43526		Beta Flange Assembly - 8 inch Triclover (Polypropylene)
CRL-44197	270	Beta Flange Assembly - 8 inch Triclover (Stainless Steel)
CRL-41911		Beta Flange Assembly - 8 inch Tri-clover (Stainless Steel)
CRL-43971		Beta Flange Assembly - 10 inch Triclover (Stainless Steel)
CRL-46765		Beta Flange Assembly - 10 inch Triclover (Polypropylene)

Inside Funnel Assembly

For protection of seal surface during transfer of materials or tools

- Mounts into the alpha port from inside the isolator

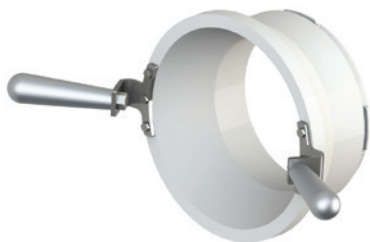

Item	Size	Description
CRL-43169	105	Inside Funnel Assembly (Stainless Steel)
CRL-41261	190	Inside Funnel Assembly (Polypropylene)
CRL-41212	270	Inside Funnel Assembly (Polypropylene)

Inside Bagging Ring Assembly

For improved low OEL performance in powder-through-port applications

- Typically, a flexible chute is attached to allow for the transfer of powder into containers or through to another process vessel
- Mounts into the alpha port from inside the isolator



Item	Size	Description
CRL-41259	190	Bagging Ring Assembly - Inside Mount (Polypropylene)

Beta Flange Wrench

For use to install or remove the beta cover from the beta flange when the container is not mated to the alpha flange

- Available for use with all standard CRL beta containers



Item	Size	Description
CRL-41114	105	Beta Cover Wrench
CRL-41115	190	
CRL-41116	270	
CRL-41117	350	
CRL-45095	460	

Beta Couplers

For interconnection of isolators or specialty equipment to a fixed alpha flange on another isolator

- For temporary connection of two process isolators



Available Sizes:

105	190	270	350
-----	-----	-----	-----

Working Diameters

The following table provides the largest diameter of an object that can be passed through the alpha and beta container for the different size containers.

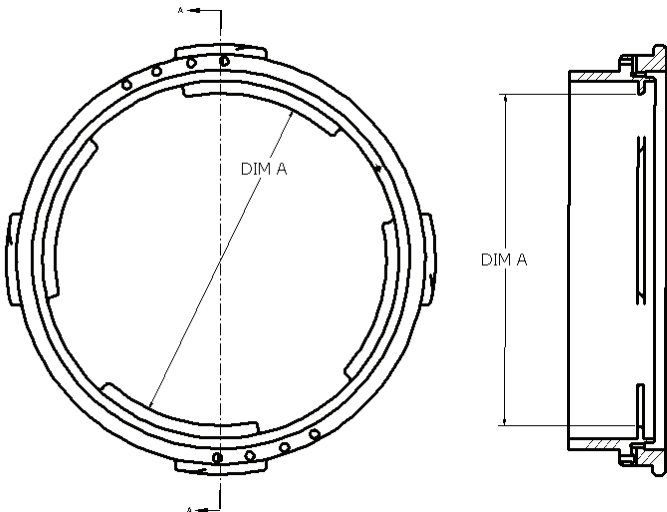

Beta Size	Material	Dimension A ([in.] mm)
105 mm	Polypropylene	[3.68] 93.47
	Stainless Steel	
190 mm	Polypropylene	[6.70] 170.18
	Stainless Steel	
270 mm	Polypropylene	[9.84] 249.93
	Stainless Steel	
	Ultem®	
350 mm	Polypropylene	[12.97] 329.13
	Stainless Steel	
	Ultem®	
460 mm	Polypropylene	[17.29] 439.16
	Stainless Steel	

Ultem® is a Registered Trademark of GE.

CRL RTP Flexible Mounts

Where the connection alignment is difficult

- For use with rotating alpha or beta flanges to enable the connection of large containers or process vessels

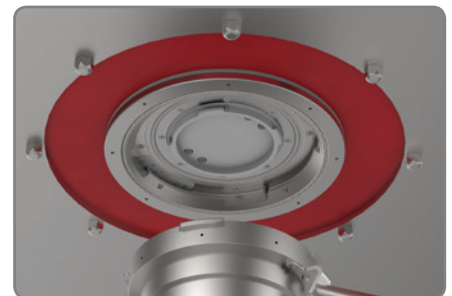

Drum Transfer System

Waste and Bulk Packaging Solutions

CRL's Drum Transfer System was developed to address the need for a safer method of transferring waste or products from isolators.

The system offers the ability to mitigate dangerous bag-out processes from the transfer and packaging of highly potent products and waste.

This patented system has been engineered to allow rapid and repeatable transfers without breaking cell containment.

- Built-in safety interlocks eliminates accidental breach of containment
- Actuated docking for fast, safe drum connect/disconnect operation
- Drum liner capable of multiple filling cycles
- Bagless RTP transfer system eliminates breach of containment while improving ergonomic safety for the operator
- 30G, 55G, or custom size drum liners available in PE or SST materials

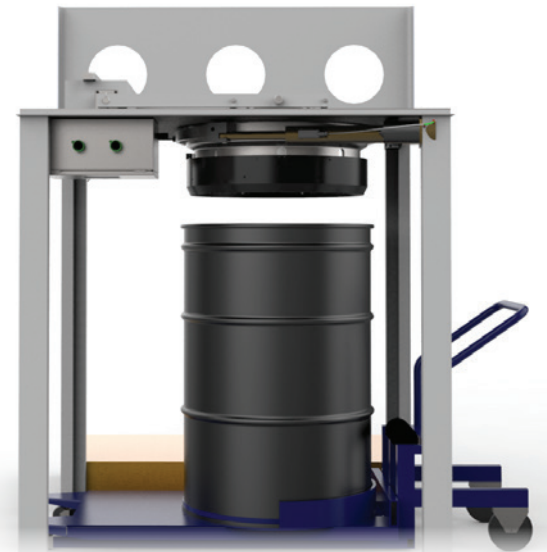

Accessories

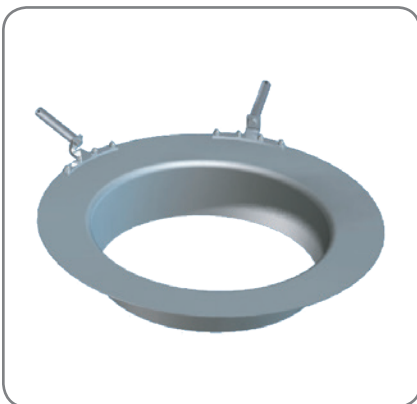

Funnel Systems



Drum & Liner Assembly



PE or SST Drum Liners Available



CRL Headquarters/Support

3965 Pepin Avenue
Red Wing, MN 55066
Tel: +1-651-385-2142
Toll Free: +1-800-934-1562
info@crlsolutions.com

crlsolutions.com