

The background image shows a large industrial facility with multiple contact part washers. The washers are arranged in rows, with metal frames and various mechanical components visible. The scene is dimly lit, emphasizing the industrial and somewhat gritty nature of the equipment.

# Contact Part washers

---

# ALL ABOUT PHARMA

WITH OVER 30 YEARS OF EXPERTISE IN TURN-KEY SOLUTIONS

**IWT offers a comprehensive range of cleaning, isolation, and decontamination solutions for the pharmaceutical, cell & gene, nutraceutical, cosmetic markets, and related industries.**

IWT specializes in the design, development, manufacture, and installation of outstanding cGMP pharma solutions. Our manufacturing base in Varese, just a few kilometers away from Milan Malpensa International Airport, spans over 20,000 square meters (215,000 square feet) of production areas, R&D, design studios, training, testing, and showroom facilities.

Our production departments are equipped with state-of-the-art laser cutters, orbital welders, and robots for processing stainless steel parts. The warehouse, fully automated in alignment with the most stringent cGMP traceability requirements, features comprehensive oversight and management of products and materials. IWT offers in-house advanced 3D design and simulation technologies, as well as software programming capabilities to ensure complete fulfillment of any user requirements specifications, in terms of quality and flexibility.

Our comprehensive range of cleaning solutions includes full cGMP product contact part washers, as well as high-pressure washing systems for bulk containers in cleaning-in-place applications or cabins for bulk parts and containers cleaning-out-of-place.

Multipurpose modular aseptic isolation technologies are at your disposal, ranging from sterility testing to component preparation, from fill-finishing to Advanced Cell & Gene Therapies.

A decennial expertise in cold decontamination methods, decon chambers and airlock systems, ensures safe and efficient material transfer through physical barriers and differently classified areas.

Both our Isolation and Decontamination product ranges ensure complete compliance with cleanroom standards according to the new EU Annex 1 requirements.

You are always welcome to visit our facilities, to experience IWT Pharma's passion and commitment firsthand, and to witness the quality and efficiency in our daily operations.





IWT Headquarters in Casale Litta (Varese, Italy). We strive to protect our surroundings and keep our ecological footprint as small as possible.

# CONTACT PART WASHERS

IWT cGMP Part Washers portfolio is engineered to perfectly clean pharmaceutical contact parts. The design is meant to minimize downtime of product lines, to eliminate any possible cross-contamination between batches and to exceed the most stringent criteria as stated in the cleaning validation protocols.

A comprehensive set of baskets and racks, standardized or tailored made, are supporting the cleaning process to guarantee items are repeatably positioned for perfect surface coverage and complete drainability. Logistic trolleys, inclusive of lifting devices for ergonomic handling, and storage racks are complementing the solutions to facilitate flows and minimize operational footprint requirements.



## 200 EVO

cGMP  
compact Part Washer



## 250 EVO

cGMP  
compact Part Washer



## 300 EVO

cGMP  
flexible Part Washer

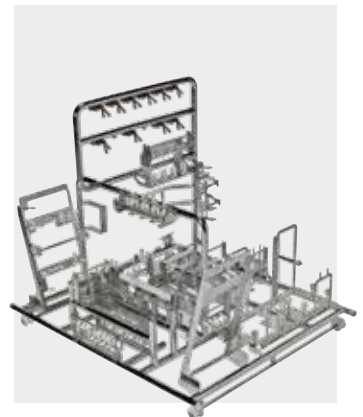

## RACKS & BASKETS

Flexi, modular and  
tailored baskets

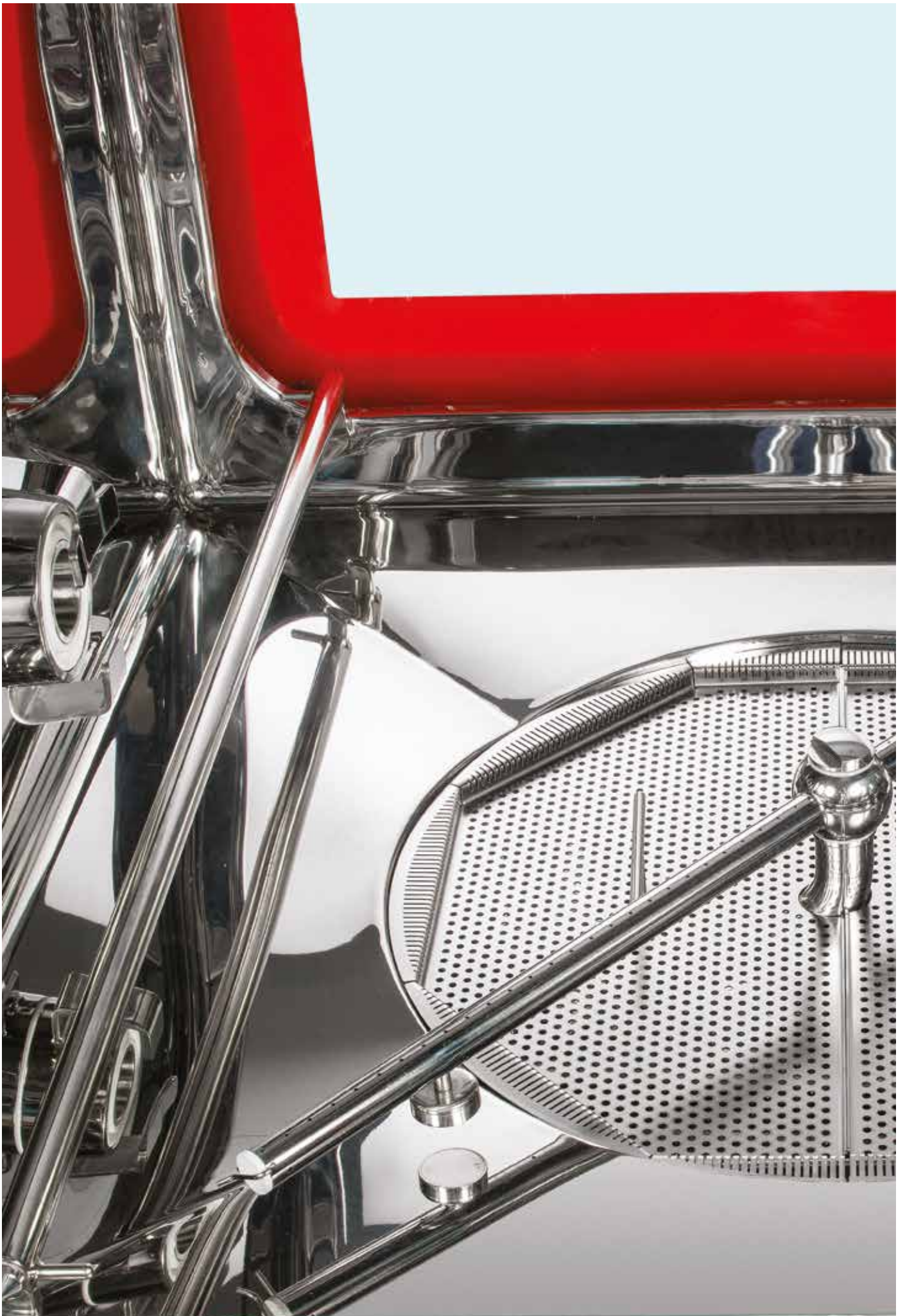

# 200 EVO - 250 EVO

## cGMP compact Part Washer

- ▶ Engineered to clean product contact parts from solid, semi-solid, liquid and aseptic manufacturing sites
- ▶ Modular design in compliance with the industry standards to allow quick turnaround projects
- ▶ Compact solution to simplify installations in existing productions minimizing any impact on current operational flows
- ▶ Multiple configurations available such as electrical or steam heating, single or double door
- ▶ Double Bioseal installation suitable for 250EVO model
- ▶ Up to 30 fully customizable washing programs from pre-washing to drying and cooling
- ▶ PanelPC configuration for remote connectivity and **INDUSTRY 4.0 integration** for programs and batch data retrieval, audit trail and log files safe storage on the customer's network
- ▶ Variable hydrodynamic control, high washing pressure and water flow tuned around every load need



▶ 200 EVO



▶ Best-in-class ratio between chamber and total volumes

MODEL	200EVO-060	200EVO-100	200EVO-140
Chamber Nominal Volume [l – gal]	622 - 164	1058 - 279	1454 - 384
Unit footprint W x D [mm - in]	1450 x 847 571 x 33.3	1680 x 1077 66.1 x 42.4	1980 x 1247 78 x 49.1
Unit height [mm - in]	2500 – 98.4		
Sump MIN working volume [l – gal]	55 – 14.5	70 – 18.5	90 – 23.8
Sump MAX working volume [l – gal]	110 – 29		

GAMP5	✓
cGMP	✓
ASME-BPE	✓
ISPE baseline	✓
FDA (including 21CFR part11)	✓
CE Marking	✓
UL Listing	✓

- ▶ **Cutting edge automation system GAMP5** compliant with ERES (21CFR Part11) and AUDIT TRAIL functions to guarantee full data integrity
- ▶ **Product contact parts** entirely made of AISI316L (1.4404). Chamber  $Ra \leq 0.5 \mu m$  and piping SF1 ASME-BPE compliant
- ▶ **Premium finishing package** ( $Ra \leq 0.4 \mu m$  and SF4 ASME-BPE) available as option for 250EVO Model.
- ▶ **HEPA filtered drying system** featuring side channel compressor under inverter management for fast drying of parts, chamber and piping
- ▶ **Multiple water inlet and chemical dosing systems** with flow meter and conductivity control
- ▶ **Process solution and water inlets sampling point.** Automatic samplingbox available for 250EVO Model.
- ▶ **Single Pass Rinse feature** via sterile compressed air booster with final conductivity control
- ▶ **Full in-house design and manufacturing of customized racks** connected via automatic quick-lock patented system

▶ 250 EVO

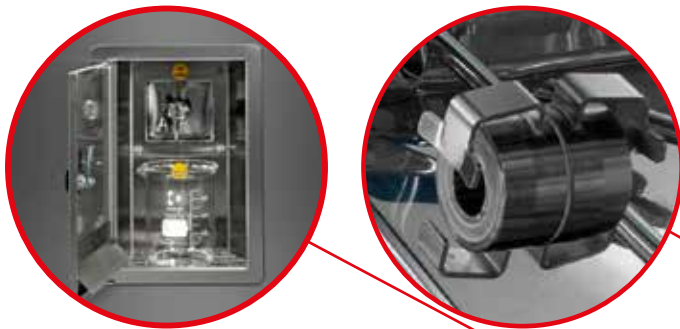

in the smallest footprint for parts cleaning:

MODEL	250EVO-100	250EVO-140
Chamber Nominal Volume [l – gal]	1058 - 279	1454 - 384
Unit footprint W x D [mm - in]	1810 x 1077 71.3 x 42.4	1980 x 1247 78 x 49.1
Unit height [mm - in]	2500 – 98.4	
Sump MIN working volume [l – gal]	60 – 15.8	
Sump MAX working volume [l – gal]	110 - 29	



# 300 EVO

## cGMP flexible Part Washer

GAMP5	✓
cGMP	✓
ASME-BPE	✓
ISPE baseline	✓
FDA (including 21CFR part11)	✓
CE marking	✓

- ▶ Engineered to clean product contact parts from solid, semi-solid, liquid and aseptic manufacturing sites, from tableting machines to sterile filling lines
- ▶ Modular design in compliance with the industry standards (cGMP – FDA – ASME-BPE – ISPE etc.) to allow quick turnaround projects
- ▶ **Two different sizes:** 1000, 1400 liters (265, 370 gal) to maximize and optimize cleaning batches



- ▶ Product contact parts entirely **made of AISI316L (1.4404)**. Chamber  $Ra \leq 0.5 \mu m$  and piping SF1 ASME-BPE compliant
- ▶ **Multiple configurations available** such as electrical or steam heating, single or double door
- ▶ **Up to 30 fully customizable washing programs** from pre-washing to drying and cooling
- ▶ **Variable hydrodynamic control, high washing pressure and water flow tuned around load needs**

- ▶ **Full in-house design and manufacturing of customized racks** connected via automatic quick-lock system



MODEL	300EVO-100	300EVO-140
Chamber Nominal Volume [l – gal]	1058 - 279	1454 - 384
Unit footprint W x D [mm - in]	2300 x 1355 90.6 x 53.3	2640 x 1525 103.9 x 60
Unit height [mm - in]	2700 – 106.3	
Sump MIN working volume [l – gal]	60 – 15.8	
Sump MAX working volume [l – gal]	110 - 29	

- ▶ **Automatic sliding glass door design to fit any operational flows.**  
Suitable for double bioseal installation



- ▶ **PanelPC configuration for remote connectivity and INDUSTRY 4.0 integration** for programs and batch data retrieval, audit trail and log files safe storage on the customer's network

- ▶ **HEPA filtered drying system** featuring side channel compressor under inverter management for fast drying of parts, chamber and piping
- ▶ **Multiple water inlet and chemical dosing systems** with flow meter and conductivity control
- ▶ **Process solution sampling point** and automatic sampling box for water inlets
- ▶ **Single Pass Rinse feature**, final conductivity control and TOC available on demand
- ▶ **Cutting edge automation system GAMP5 compliant** with ERES (21CFR Part11) and AUDIT TRAIL functions to guarantee full data integrity



- ▶ **Tool-free removable filter (mesh 16)**

# RACKS & BASKETS

## Flexi and tailored loading accessories

DESIGNED AROUND CUSTOMER'S LOAD TO GRANT PERFECT CLEANING RESULTS

Ensuring the effective and validated cleaning of a wide range of machine parts and miscellaneous items is essential to prevent cross-contamination between production batches. From drums to hoses, glassware to plasticware, filling needles to punches and dies - all components are meticulously studied to design and engineer the associated accessories to achieve the optimal exposure and to optimize the load per cycle.

The drivers in developing our solutions, regardless of standardized or tailored ones, are:

- ▶ Easy and quick filling: intuitive 1-to-1 repeatable positioning of every critical item
- ▶ Full coverage and drainability
- ▶ Precise flushing of the smallest and hidden areas
- ▶ Perfect drying results of racks and related loads

A comprehensive portfolio of accessories completes the logistics solutions thought to improve ergonomics in handling racks and parts minimizing the operational footprint requirements.

Transport trolleys, inclusive of lifting systems, enhance accessibility for operator's ease of loading/unloading as well as warehouse systems for efficient basket storage.

## SOME OF THE APPLICATIONS:



Sterile filling needles



Hoses



QC glasswares/plasticwares



Tableting machine



Punch & Die sets



Drums

# Tailored baskets

IWT tailored racks and baskets are designed around the client's specific set of parts. The 3D modelled items are deeply analysed not only to ensure the best positioning for optimal cleaning and drying but also to engineer the best support method which aims to guarantee the safe holding in position without compromising the original product quality, the ease and ergonomics of handling for any operator and a proper frame sizing to cope with the labour intense activities in busy production lines. High density and batch optimizations are key drivers to deliver the personalized solution fitting clients' needs.

Via a tight collaboration with customers, the tailored racks can be studied to maximize the loading capacity and batch optimization so to perfectly fit operational flows and needs resulting in outstanding downtime reductions.



3D SCANNING for custom parts and MEASUREMENTS CHECKS for standardized components

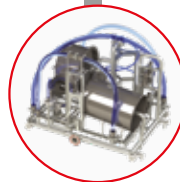

3D PARTS MODELING AND POSITIONING, BATCH OPTIMIZATION STUDIES AND FLUIDODYNAMIC COVERAGE SIMULATIONS

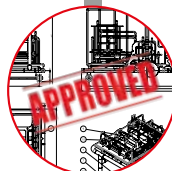

CUSTOMER'S APPROVAL of the detailed proposal design



SHOP-DRAWINGS ELABORATION AND RELATED MANUFACTURING STEPS inclusive of mandatory traceability and quality controls



RACK INTERNAL INSPECTION, TEST AND CUSTOMER'S FAT APPROVAL



CLEANING TEST BY MEANS OF RIBOFLAVIN with final load in operative conditions

## Flexi and Modular baskets

IWT Flexi and Modular racks are engineered to be assembled and built up starting from the client's mix of parts. The long IWT experience in designing and manufacturing tailored baskets allows us to develop standardized solutions capable to fit the most common and repeatable items typically present in the GMP production lines. Flexi and Modular baskets thanks to their repeatable design guarantee fast projects, ease of management and smooth validation.

- ▶ Standardized frames with easy plug-in connection points to integrate specific cleaning kits
- ▶ Flexy racks to process bulky components and miscellaneous items
- ▶ Modular racks for performing cleaning of known and repeatable parts (custom models available via feasibility study)
- ▶ Ease of access to the load with optimized density
- ▶ Adaptable design to accommodate various labware shapes and sizes
- ▶ Full GMP design with material certificates 3.1, traceability and validation protocols
- ▶ Basic frame connection points and individual kits univocal ID marking for cross-reference and validation purposes
- ▶ Quick turnaround projects with off the shelves designed and validated modules
- ▶ Possibility to integrate further kit at need later in the project with a lower general investment

### **SELECT YOUR MODULES. CREATE YOUR BASKET.**

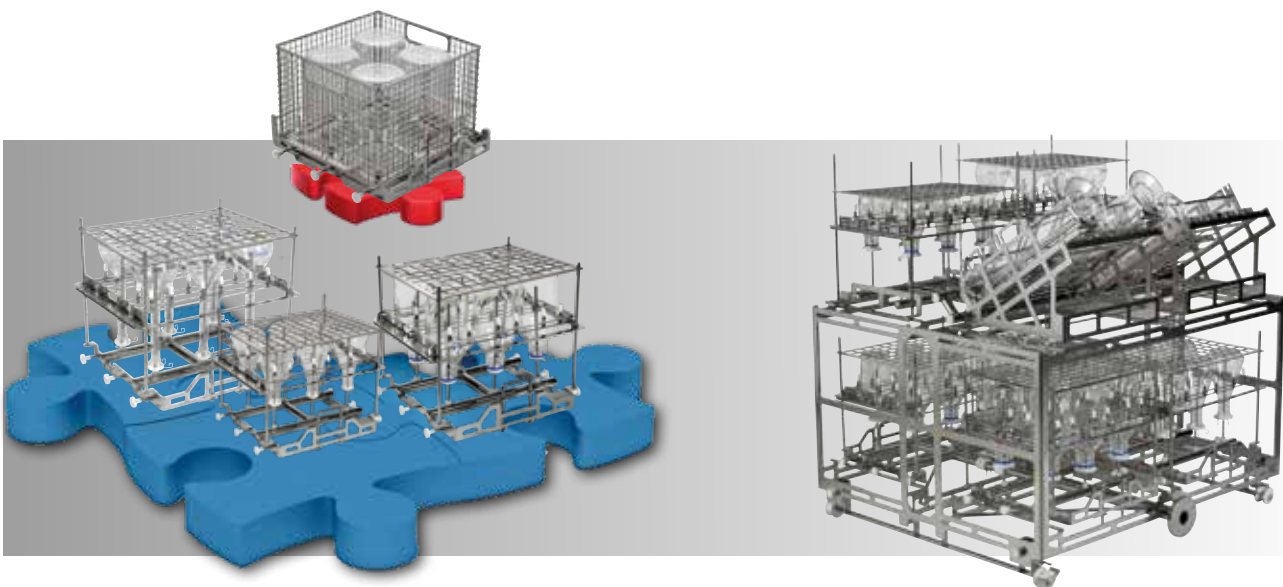

**FAST PROJECT.**  
**EASY OF MANAGEMENT.**  
**SMOOTH VALIDATION.**



► Drawer style modules for ease of access

**SOME EXAMPLES**

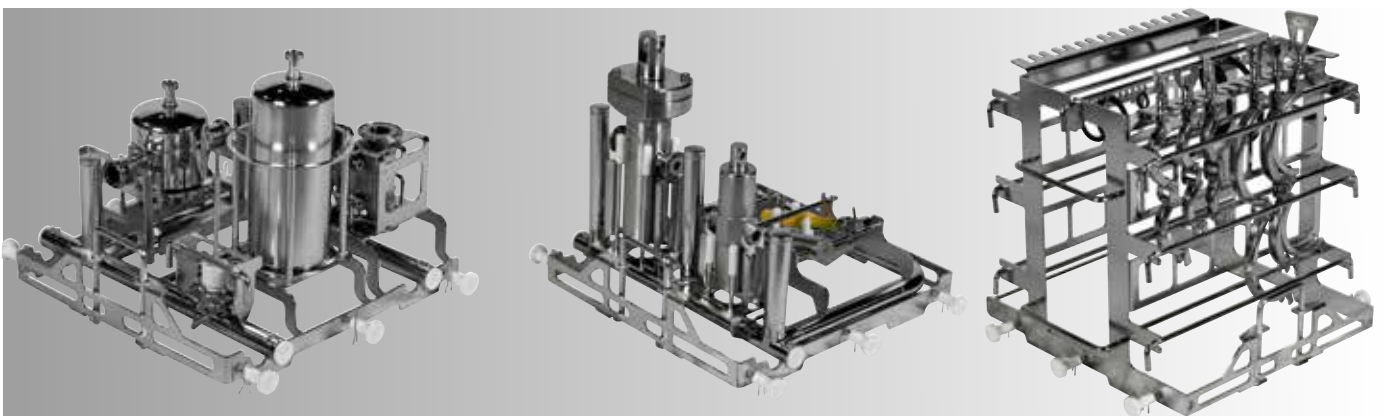



► Custom example

► Custom example

# WE OPERATE LOCALLY. **WORLDWIDE.**



-  IWT Headquarters and production site
-  Group Subsidiaries and commercial offices
-  Dealers/Agents

Being a global company, as part of the Tecniplast Group, means we are well aware of the challenges the world is facing.

Our worldwide network of Subsidiaries, Dealers and Agents allows us to understand different cultures, languages and needs, thus perfectly responding to regional expectations.

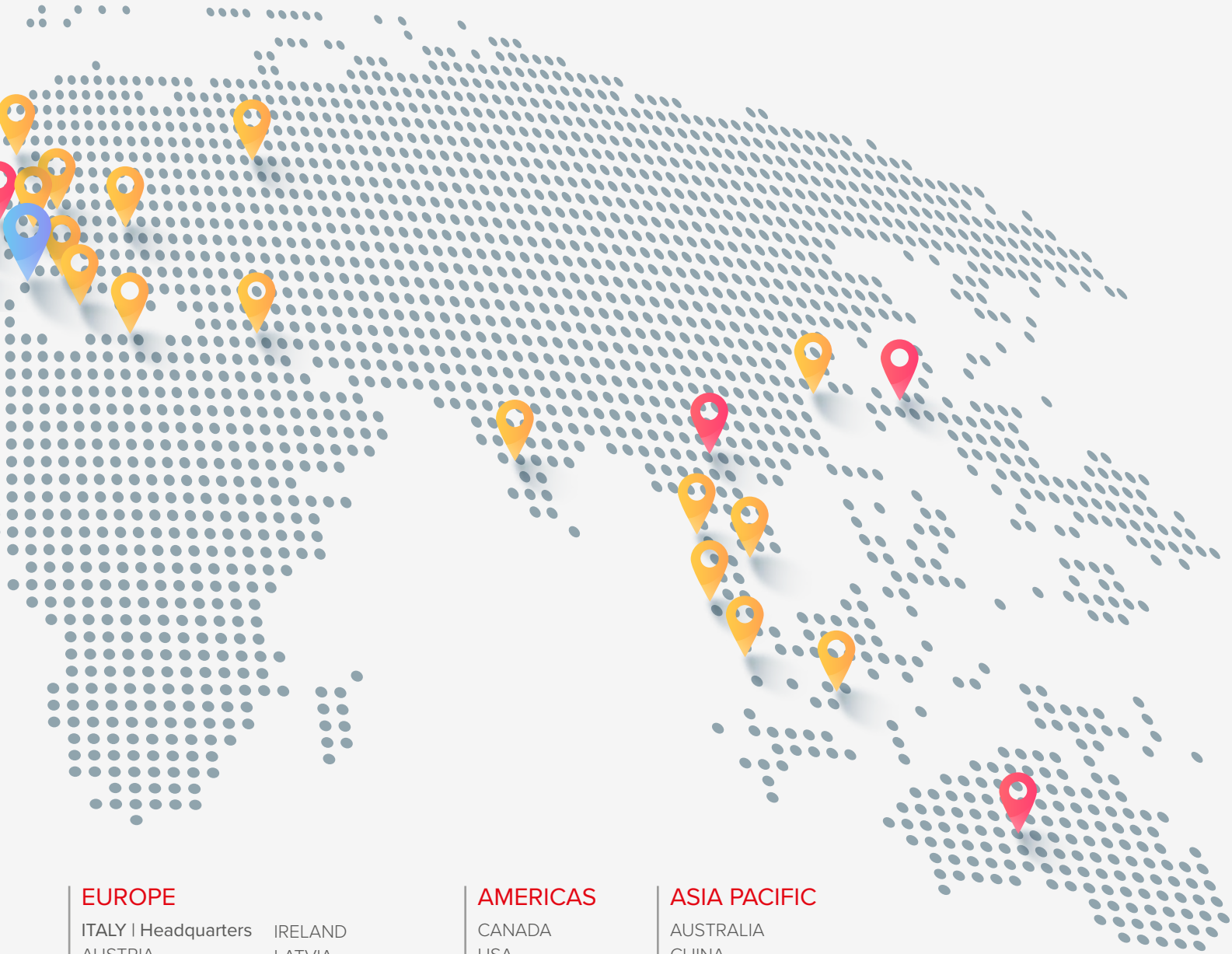

**EUROPE**

- ITALY | Headquarters
- AUSTRIA
- BELARUS
- BELGIUM
- CROATIA
- CZECH REPUBLIC
- DENMARK
- ESTONIA
- FRANCE
- GERMANY
- GREECE
- HUNGARY
- IRELAND
- LATVIA
- MALTA
- POLAND
- PORTUGAL
- RUSSIA
- SLOVAKIA
- SPAIN
- SWITZERLAND
- THE NETHERLANDS
- UKRAINE
- UK

**AMERICAS**

- CANADA
- USA
- ARGENTINE
- BRAZIL
- CHILE
- COLOMBIA
- MEXICO
- URUGUAY

**ASIA PACIFIC**

- AUSTRALIA
- CHINA
- INDIA
- INDONESIA
- JAPAN
- MALAYSIA
- SINGAPORE
- SOUTH KOREA
- THAILANDIA
- VIETNAM

**50+**  
Countries

**325M**  
annual Group turnover

**400+**  
installations

**1,500+**  
employees worldwide



## Contamination Control Excellence

**iwat**  
TECNIPLAST GROUP

**HEADQUARTERS IWT s.r.l.**  
Tel. +39 0332.96701  
[www.iwtpharma.com](http://www.iwtpharma.com)  
[info@iwtpharma.com](mailto:info@iwtpharma.com)



CAT MKTRC00011F - - Rev March 2026  
IWT SRL Società unipersonale / Sede legale e amministrativa: via Galliani 68b  
21020 CASALE LITTA (VA) ITALY • CF: e P.IVA: IT 02002720122  
IWT reserves the right to change or modify product and/or specifications without notice or obligation.